



think SPEED think GiDEL™

PRELIMINARY INFORMATION
October 2008

PROCe III™ PCIe x4 Computation Accelerator

Key Features

- Stratix III 80E, 110E, 260E, 150L or 340L FPGAs
- 4-lane PCI Express (PCIe x4) host interface
- **Five level memory structure (supports 16.5 GB+).**
Maximum memory sustain access rate is **2,750 GB/s** to internal memories and **8.8 GB/s** to DRAMs as follows:
 - ✓ Up to 1040 M9K (9K-bit) DPRAM blocks
(1.1MB with access up to **2.496 GB/s @ 300Mhz**)
 - ✓ Up to 48 M144K (144K-bit) RAM blocks
(0.8MB with access up to **259 MB/s @ 300Mhz**)
 - ✓ Up to 6,750 MLAB (640-bit) RAM blocks
 - ✓ A 512 MB DDR2 memory with **4 GB/s** sustain access for up to 16 ports
 - ✓ 2 DDR2 SODIMMs with up to 4 GB each at a maximum sustain access rate of **4.8 GB/s** (designed to support 8GB SODIMMS when will be available)
 - ✓ Onboard SRAM options on SODIMM modules
- Supports 2 PROCe III Daughter Boards:
Camera Links, User's Ethernet and other interfaces
- Typical system frequencies: 150-350 MHz.
- Flexible clocking system.
- Volatile and non volatile design security
- Supported by GiDEL's **PROC Developer's Kits**
- Option for Ethernet stand-alone mode

Benefits

- Leading edge performance
- Advance development tools
- Low power consumption
- Maintainability
- Reliability
- Long life cycle



Overview

The **PROCe III™** system provides a high-capacity, high-speed FPGA-based platform fortified with high throughput and massive memory resulting in a powerful and highly flexible system. The **PROCe III** can be hosted via 4-lane PCI Express. The performance, memory and add-on daughter boards' flexible architecture enable the system to meet almost any computation needs. In addition to 512MB on-board memory, two SODIMM sockets provide up to 8GB of memory or additional connectivity and logic. Abundant memory conjoined with fast PCIe connection enable strong co-processing between a standard PC operating system and the FPGA acceleration. The **PROCe III** system, with GiDEL's **PROC Developer's Kit** and tools, offers an incredible performance yet supports quick implementation of your unique design. It is done by eliminating the need for a high-speed board design, a PCI Express application driver, board constraints and environment FPGA code. The generated HDL code enables high throughput, easy-to-use parallel access to large memories. As a result, designers can focus on their proprietary value-added design. User designs may be in HDL, C-based, Simulink (graphical design) or any combination of them.

Development Environment

The *PROCDeveloper's Kit*, GiDEL's intuitive design and debug environment, facilitates design development effort on the *PROCe III* system. The kit contains *PROCWizard*TM, *PROCMultiPort*TM IPs, *PSDB_Proto*TM, *USBBlaster*, and a *PROCHIL*TM option.

The *PROCWizard* performs hardware initialization and automatically generates the following:

- Interface documentation in HTML or Microsoft Word.
- C++ class(es) application driver(s) enable simultaneous accesses of multiple applications, each to its' dedicated section of the PROC board.
- Top-level designs, interface modules / entities and on-board memory controllers for the application use.
- Device constraints (as pin-outs).

The *PROCMultiPort* core IPs provides simple access as FIFOs and frame delays to the on-board DRAM. It enables parallel access to the on-board memory while enabling to split the physical memory into multiple logical memories. As a result the main benefits are:

- Simplifies design and enhances system performance.
- Replaces the need for inventory of special memories by using standard memory and IP.

The *USBBlaster* enables visibility of internal signals using the available FPGA memory.

PROCe III Performance examples

Algorithm	Data flow	% critical resource of Stratix III logic		
		80E	110E	150L
1024*1024 FFT Width 12 bit Transform time 5.7mS	370 MHz	11%	8.2%	10%
9*9 filter symmetric 12 bit data 16 bit coefficients	336 MB/s	1%	<1%	<1%
7*7 8bit Median filter	255 MHz	11%	8.4%	6.3%
Circle open / close with radius up to 15 pixels 8 bit per pixel	323 MHz	5%	3.8%	2.9%
Threshold, add, subtract, 10→ 8 LUT,	>> 640 MHz	<< 1%	<< 1%	<< 1%

* Due to the different resource usage, better utilization is expected in a full design.

* For faster operation, use a multi-channel design.

* For 260 and 340L performance data, contact GiDEL.

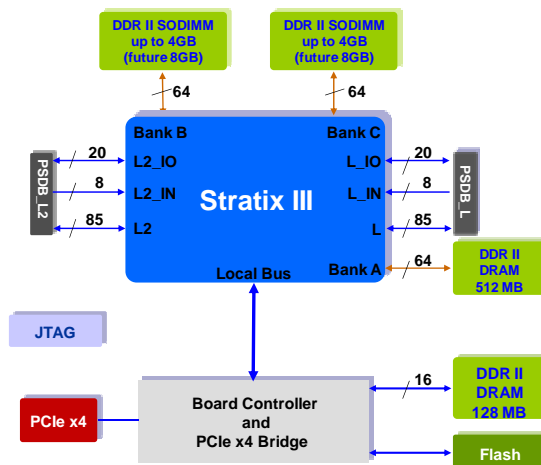

PROCe III board diagram



www.gidel.com



立野電腦 EXT營業部

E-mail: sales@dsp-tdi.com

〒198-0063 東京都青梅市梅郷5-955 TEL.0428-77-7000 FAX.0428-77-7010

URL <http://www.dsp-tdi.com/>

Japan:

〒198 - 0063 東京都

青梅市梅郷5 - 955

Tel: 0428 - 77 - 7000

Fax: 0428 - 77 - 7010

Email: sales@dsp-tdi.com

USA:

1600 Wyatt Drive Suite 1
Santa Clara, CA 95054, USA

Tel: 1 - 408 - 969 - 0389

Fax: 1 - 866 - 615 - 6810

Email: sales_usa@gidel.com